

Retail - Floor Plan

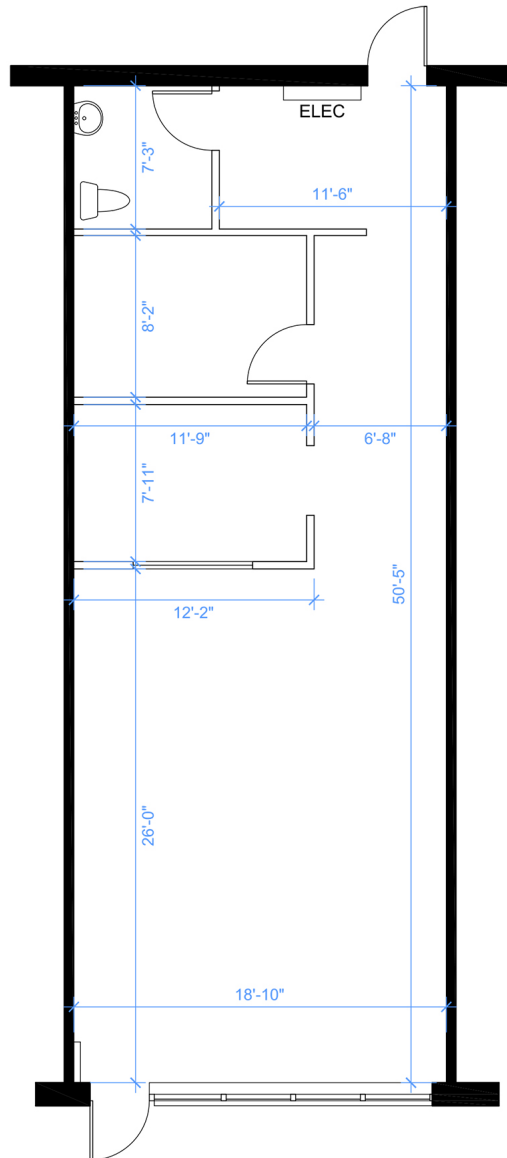

WALL THICKNESSES OF UNIT BOUNDARIES AT COMMON AREAS AND DEMISING WALLS ARE ESTIMATED



UNIT 7
RENTABLE AREA = 1,081 SF
RENTABLE AREA PROVIDED BY METRUS

LOCATION:

1530 Major MacKenzie Dr.
City of Vaughan



FOR MORE INFORMATION, PLEASE CONTACT:

Antoinette Grossi
Director of Leasing

905.669.9714
agrossi@metrusproperties.com